

PRH FOR CUBE MOLD

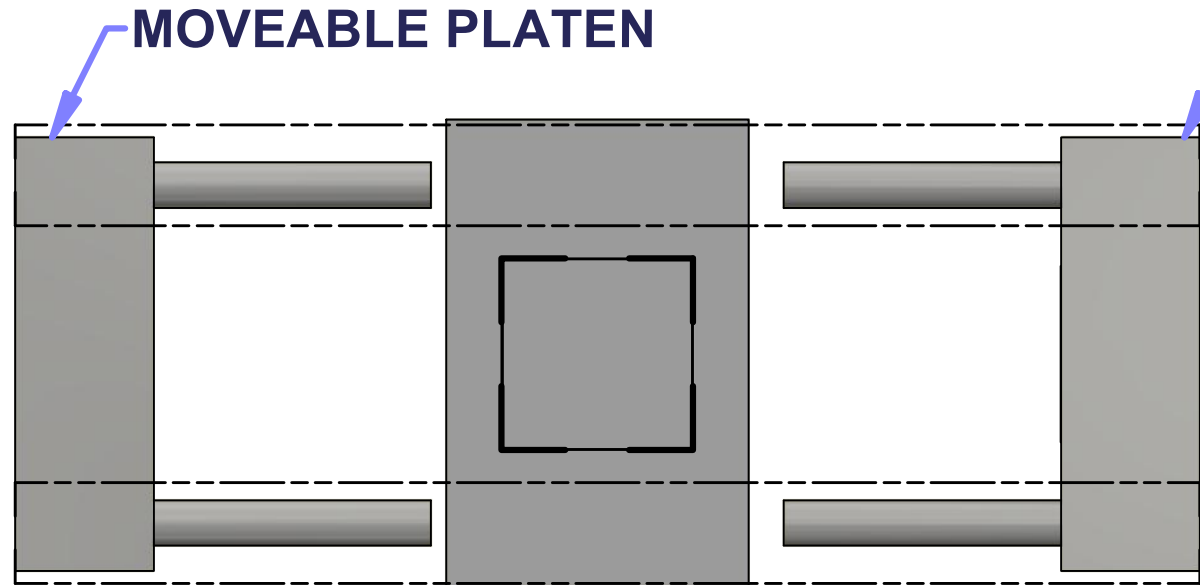
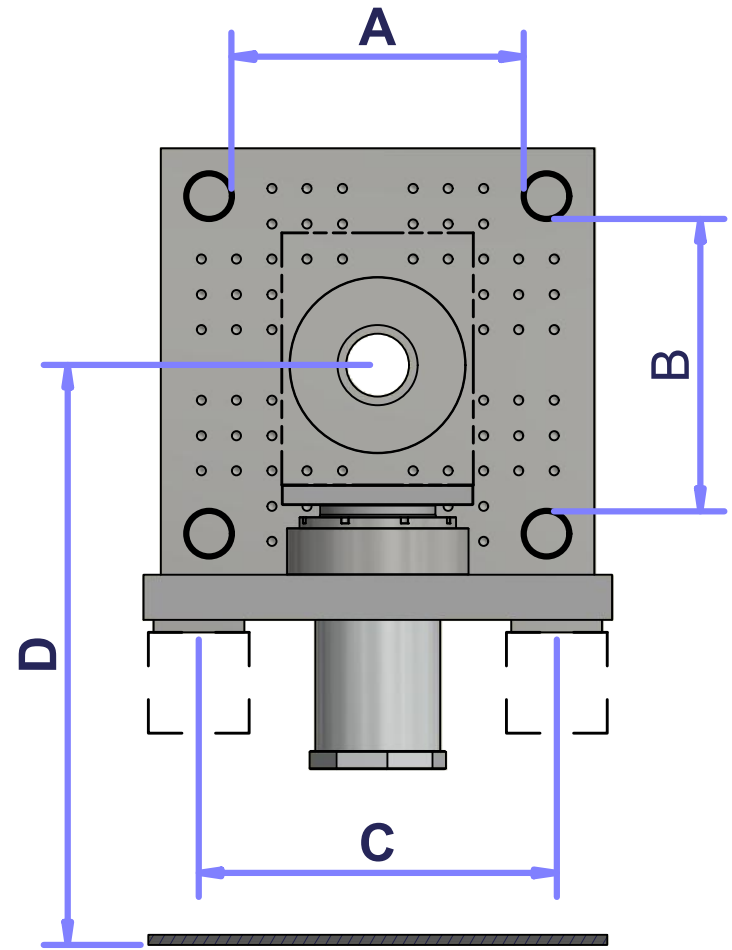
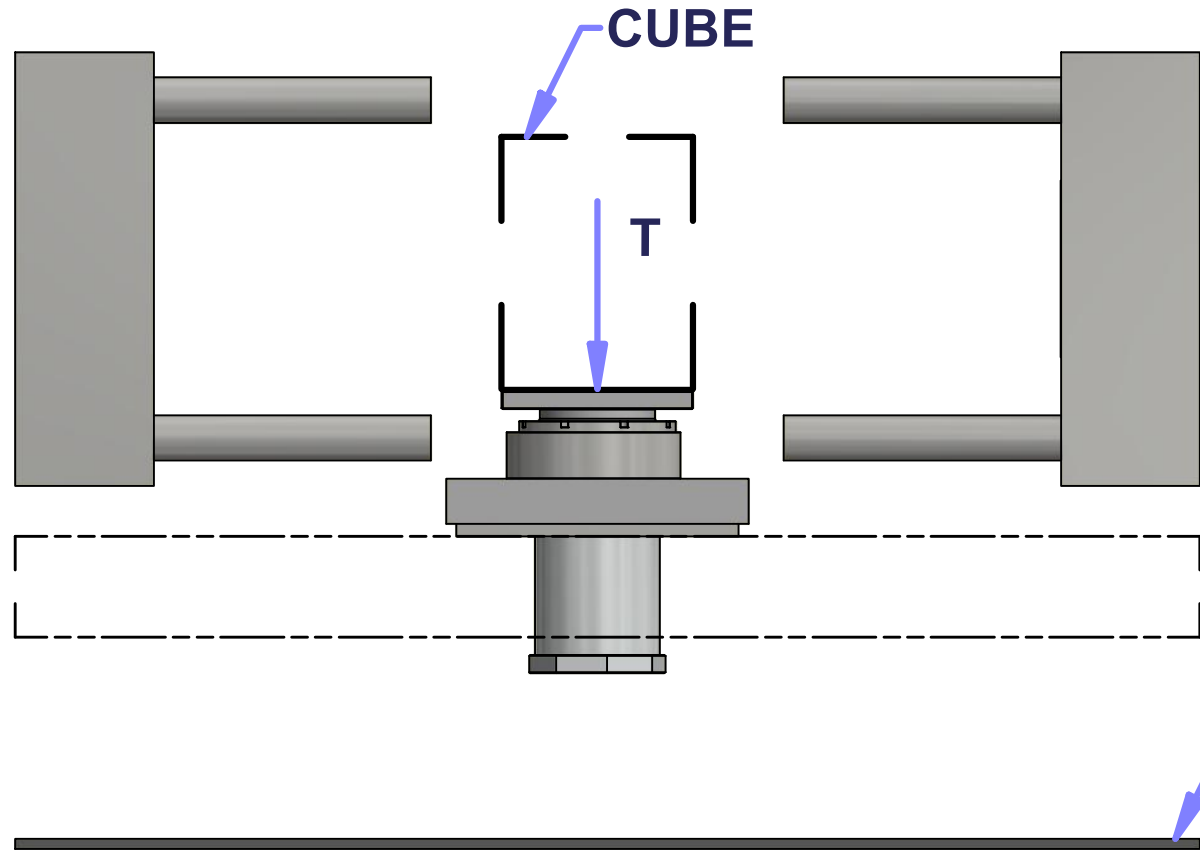

IMM FLOOR REMOVED FOR CLARITY

SPECIFICATIONS	
A	
B	
C	
D	
T MAX. CENTRAL TOOL WEIGHT (Kg)	
MINIMUM ROTATION TIME / INDEX ANGLE	_____ s / _____ °
INJECTION MOULDING MACHINE (IMM)	
MOULD STROKE (mm)	
4 WATER CIRCUITS (4 IN'S & 4 OUT'S, 85° Máx at 6 bar)	
4 OIL CIRCUITS (4 IN'S & 4 OUT'S, Máx 140 bar)	
ELECTRIC SLIP RING (ESR)	___ 6 WAYS / ___ 12 WAYS